



WP-32 Pouch Machine

- Ultra high-speed servo drive system for producing more than 1,200 packages per minute.
- Idle mode allows machine to be stopped and started with no loss of product or packaging materials.
- Package features such as easy-open notches and perforations, pouring spouts, drip-resistant openings makes packages as “user-friendly” as possible.
- Accurately fills products as thin as soy sauce and as thick as peanut butter. The WP-32 is a perfect fit for food, dairy, cosmetic, industrial and pharmaceutical products.
- Patented “Atmospheric Control” option provides superior hot fill performance for modified atmospheric packaging.
- Particulates up to 3/4” (19mm).
- CIPable filling system and complete tank, valve, piping and control systems now available.
- Recipe feature provides instant electronic loading of saved parameters for product changeovers at the push of a button.
- New tubular shaped packages waste dramatically less packaging material and less seal area to package products.
- Saves more than 10 percent of packaging materials, which positively demonstrates environmentally sound practices and significantly reduces operational costs.
- 30 percent fewer seals means greater seal integrity and the face-to-face fin seals ensure that product will never have incidental contact with inks and other adulterated products that exist in the raw edges of packaging materials used in lap or butt sealed packages.
- WPD-32 available with volumetric or auger fillers for dry products.

The Winpackage System employs the most efficient package shape, packaging materials and packaging machinery on the planet...





MACHINE SPECIFICATION	WP-32
FILM WIDTH	Up to 32" (812.8mm)
PACKAGES PER CYCLE	4 to 12
PACKAGE WIDTHS	1.0" (25.4mm) to 4" (101.6mm)
PACKAGE LENGTHS	Minimum 2" (50mm) Maximum 9" (228mm)
CYCLES PER MINUTE	15 to 100
FILL VOLUME RANGE	Minimum 0.1 fl. oz. (3ml) Maximum 10 fl. oz. (285ml)
FILL TEMPERATURE RANGE	Minimum 34°F (1°C) Maximum 195°F (90°C)

Made from a single roll of laminated plastic packaging material, multiple packages are formed into tubes, filled with liquid products, hermetically sealed and cut into individual packages. The laminations within these packaging materials allow selection of product protection and appearance performance parameters to create the lowest possible cost packages. The finished packages typically have pre-printed graphics on the front and back, in a unique wrap-around format, which allows for complete freedom in designs including ample room for ingredient panels.

Using proven technologies in combination with new systems that required five years to develop, servo driven robotics produce up to 1,200 of these packages per minute at unprecedented efficiencies! Exclusive features such as "idle" mode in concert with up to 28 hours of run time between roll changes, dramatically increases efficiency.

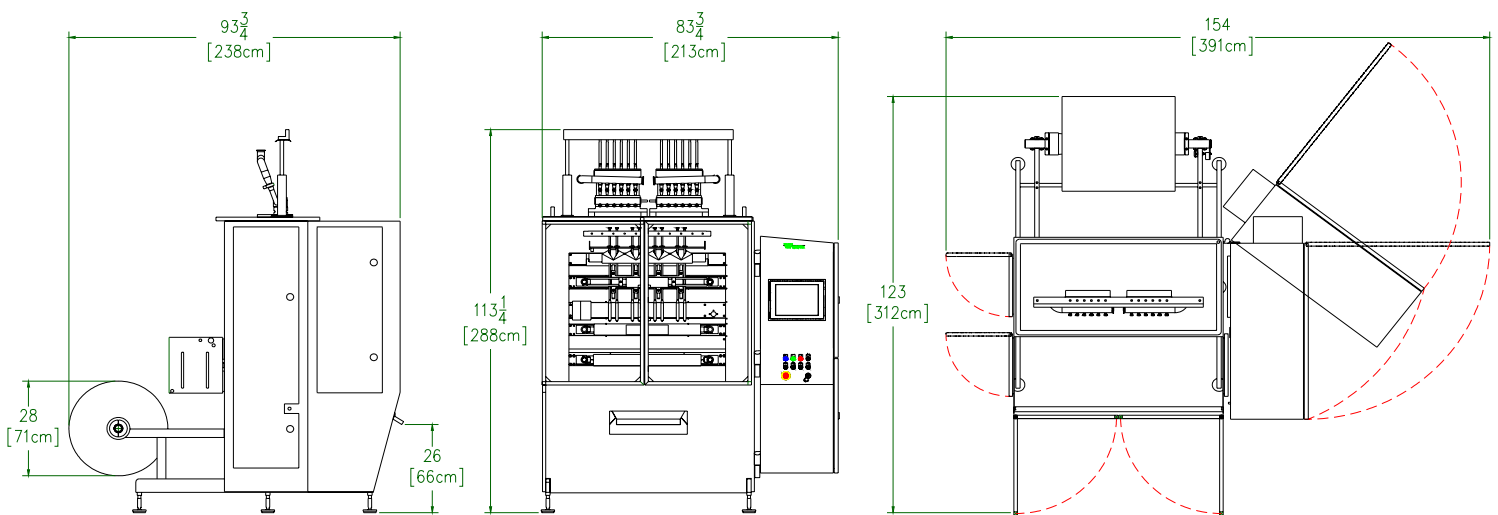

Winpak Lane, Inc.
 998 S. Sierra Way, San Bernardino, CA 92408
 Tel: (909) 885-0715 • (800) 804-4224 • Fax: (909) 381-1934
 e-mail: sales@wli.winpak.com • www.winpak.com